

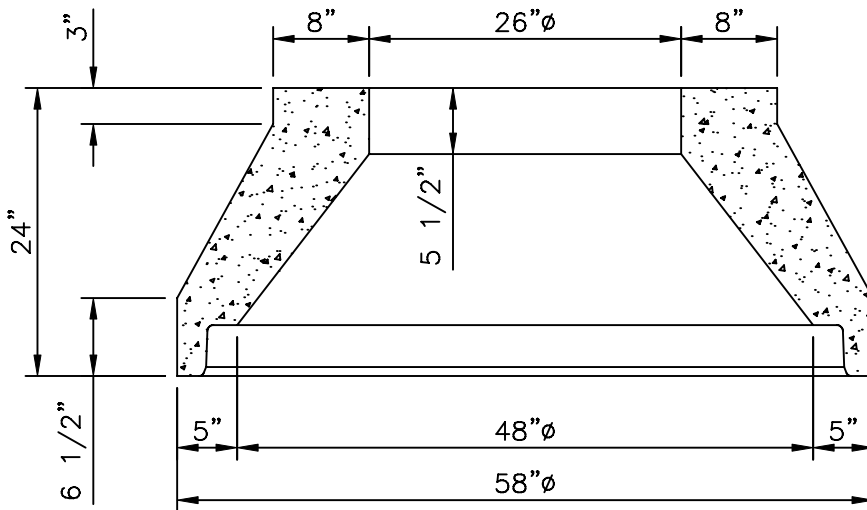

8650 Box Rd.
 Shreveport, LA 71106
 Phone: 318-869-2085
 Fax: 318-869-2098
 800-456-1970

DESIGN & CONSTRUCTION NOTES

1. PRECAST M.H. IS DESIGNED TO ASTM-C-478-88A
2. 5,000 PSI CONCRETE IN 28 DAYS.
3. REINFORCING STEEL DEFORMED BARS CONFORMING TO ASTM SPECIFICATION A615.
4. ALL JOINTS SEAL WITH PRESS-SEAL G4 GASKETS
5. INTERIOR COATED WITH COAL TAR EPOXY 12-14 MILS.
 EXTERIOR COATED WITH BITUMINOUS COATING 10 MILS.

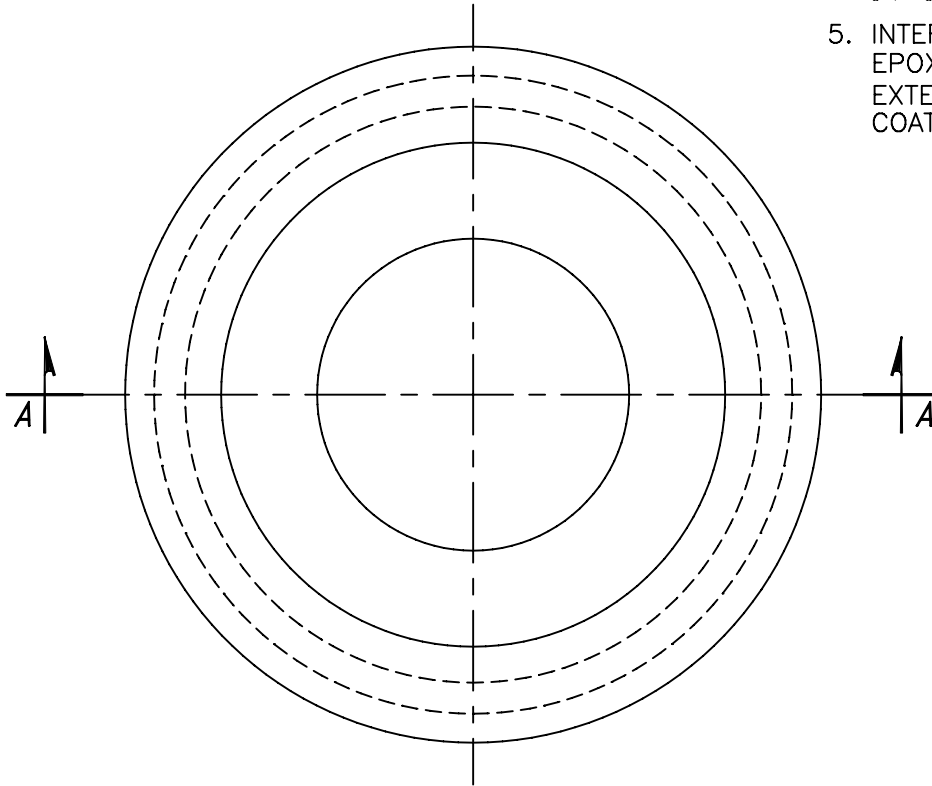

SECTION "A"-"A"

48"Ø CONCENTRIC M.H.	
DRAWN BY: KWD	APP'D BY: SN
DATE: 1/2/07	SCALE: 3/4"=1'-0"