

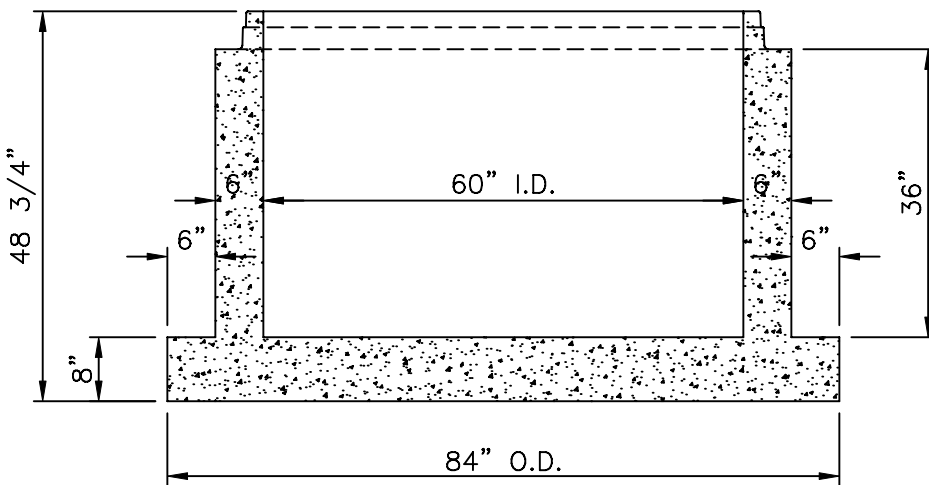

8650 Box Rd.  
Shreveport, LA 71106  
Phone: 318-869-2085  
Fax: 318-869-2098  
800-456-1970

### DESIGN & CONSTRUCTION NOTES

1. PRECAST M.H. IS DESIGNED TO ASTM-C-478-88A
2. 5,000 PSI CONCRETE IN 28 DAYS.
3. REINFORCING STEEL DEFORMED BARS CONFORMING TO ASTM SPECIFICATION A615.
4. ALL JOINTS SEAL WITH PRESS-SEAL G4 GASKETS
5. INTERIOR COATED WITH COAL TAR EPOXY 12-14 MILS.  
EXTERIOR COATED WITH BITUMINOUS COATING 10 MILS.

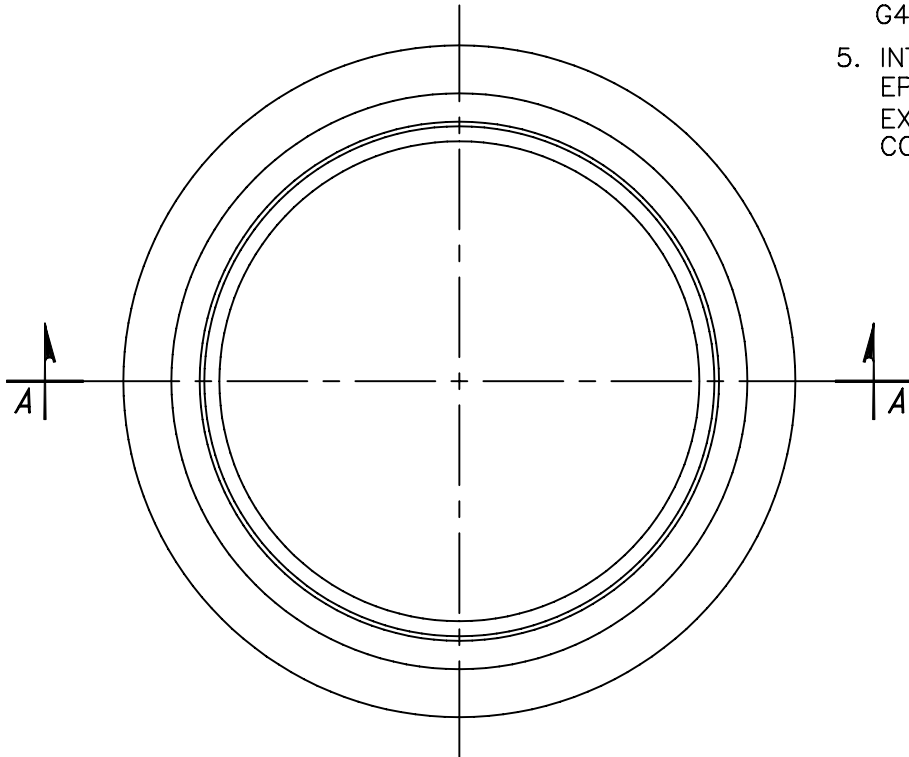

SECTION "A"-"A"

**60"  $\phi$  x 36" BASE M.H.**

DRAWN BY: KWD

APP'D BY: SN

DATE: 1/4/07

SCALE: 1/2"=1'-0"